

Rayeman Grain Cooling System

The **Rayeman Grain Cooling Systems'** patent pending technology safely and efficiently cools various grains, and similar residuals, from high to lower temperatures in a process that preserves the highest nutritional properties in the grain, ultimately yields the lightest and best color grain, and de-clumps and creates flowable grain that won't bridge.

The **Rayeman Grain Cooling System** features unique sets of counter-rotating, intermeshing twin screws enclosed in a barrel, in combination with a central water chilling system of temperature controlled zones. The chilling system contains a water based cooling medium that circulates in a closed loop on the barrels' surface, creating conductive/inductive cool transfer from the barrel to screws, and directly to the material.

Distillers grain is fed from a hopper, and distributed in a thin layer over the high surface area of the chilled screws. The temperature controlled screws convey the grain through the barrel, passing it through a series of temperature controlled cooling zones, which adjusts the grain to the desired temperature.

Rayeman Grain Cooling System

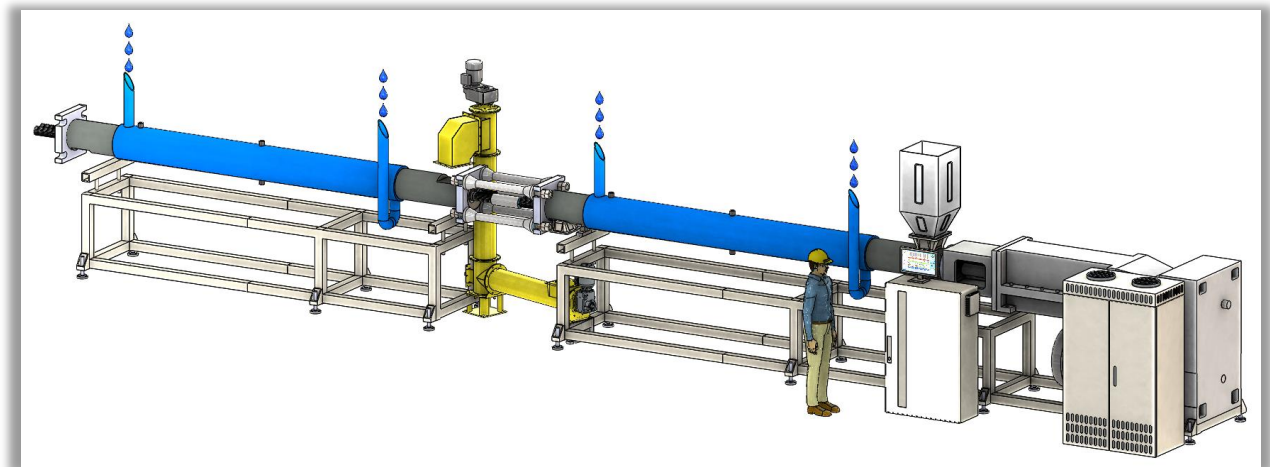

The **Rayeman Grain Cooling System** is unmatched in its flexibility for effectively cooling grain.

System Performance

This system will demonstrate the effectiveness of cooling grains at the desired output capacity, whether wet distillers grain coming off the distillation process, or dry distillers grain coming off a dryer. The cooling system can take on moisture levels in the range from 95% down to 5%.

Additional benefits of the Rayeman Grain Cooling System

- allows for temperature control of both the screws and barrel to maintain desired cooling temperature
- can be hooked up to your existing dryer system, or to the Rayeman Compression Dryer
- “de-clumps” dry grain
- prevents the grain from burning
- preserves the nutrients in the grain
- produces a lighter colored grain
- allows for steady, flowable grain

Configurations

The **Rayeman Grain Cooling System** is designed to be flexible, dependent on desired output and temperature. The barrel and screw arrangements can be hooked up in series, or in a parallel configuration, with grain being distributed to subsequent sections via conveyors.

Calculations based on:

- Input - Dry Distillers Grain at 12% moisture content, on average
- Output - Dry Distillers Grain at 12% moisture content, on average
 - Operating cost to cool grain estimated at \$2.50/ton @ 0.07 KWH = 35 KW/ton
 - Water chiller system operating at +40F
 - Material temp from +180F to +100F

Dry Output Capacity/day	Screw Size (mm)
100 - 300 tons	160mm
301 - 600 tons	235mm
601 - 900 tons	320mm
901 - 1500 tons	360mm

At Rayeman Elements, we strive to be the leaders of the industry not only for our technology and innovations but for our dedication and commitment to you.

Please contact us for more information, and to discuss your project requirements.