

# Rayeman Bulk Densification Equipment

**Rayeman Elements'** ground-breaking, patented **Bulk Densification** technology and equipment provides the opportunity to bulk densify nearly any product introduced, reducing the footprint of the material by up to 70%, forming a cube, pellet, or log (pictured below) for feed, renewable and/or alternative energy products, or shipping purposes.



**Rayeman Bulk Densification Lines** feature unique sets of counter-rotating, intermeshing screws that act as a positive displacement pump when rotated inside a temperature controlled, enclosed barrel. The screws compress and release the material several hundred times from the beginning to the end of each zone.

The compressed material is forced under pressure into a die plate that distributes the compressed material into multiple shaping holes, which forms and extrudes the cube, pellet, or log as it proceeds through a closed loop cooling chamber, before being cut to an adjustable size.

## Rayeman Bulk Densification Equipment



### Bulk Densification for Cattle Feed

**Rayeman Bulk Densification Lines** process 100% distillers or brewers grain with no added fillers or binders. Mechanical heating through shearing and rotation of the screws and 3 dimensional pressure creates a cube or pellet which does not fall apart during auguring or shipping to the rancher. The resulting cube, pellet, or log product maintains the highest nutritional properties in the grain, dimensional stability during shipping, and less than 2% loss from manufacture to dinner.

### Bulk Densification for Wood and other Renewable or Alternative Energy Products

Through our densification process and technology, pellets or briquettes are produced from multiple materials including, but not limited to, dried/undried woods, multiple feedstocks, or residuals left in the field after harvest, that are water-resistant, non-abrasive, cleaner burning and more economical for shipping. This technology offers significant applications in:

- coal fire energy plants for electric power generation
- wood pellet burning furnaces for home heating
- boiler systems for hot water/steam in manufacturing plants

# Rayeman Bulk Densification Equipment

## Bulk Densification for Overseas and Long Distance Shipping

Bulk densified materials are moisture resistant, easier to handle, allow for a greater weight by volume, and assure considerably less loss or rejection upon delivery, making it extremely economical.

### Additional benefits of installing Rayeman Bulk Densification equipment:

- can be hooked up to the Rayeman Compression Dryer, or to your existing dryer system
- the opportunity to diversify your revenue stream
- improves and expands current market segments
- creates new industries

### System Performance

The system provided will demonstrate the effectiveness of producing cubes, pellets, or logs that are dense enough to prevent breakage in transit, while maintaining the highest nutritional properties in the grain, as well as dimensional stability.

### Configurations

The **Rayeman Bulk Densification Line** is designed to be flexible, dependent on desired output.

Calculations based on:

- Input - Dry Distillers Grain at 12% moisture content, on average
- Operating cost - \$2.99/ton @ \$0.07/KWH = 43 KW/ton

Output Capacity/day	Screw Size (mm)
72 tons	160mm
400 tons	260mm
1000 tons	320mm

## Rayeman Bulk Densification Equipment

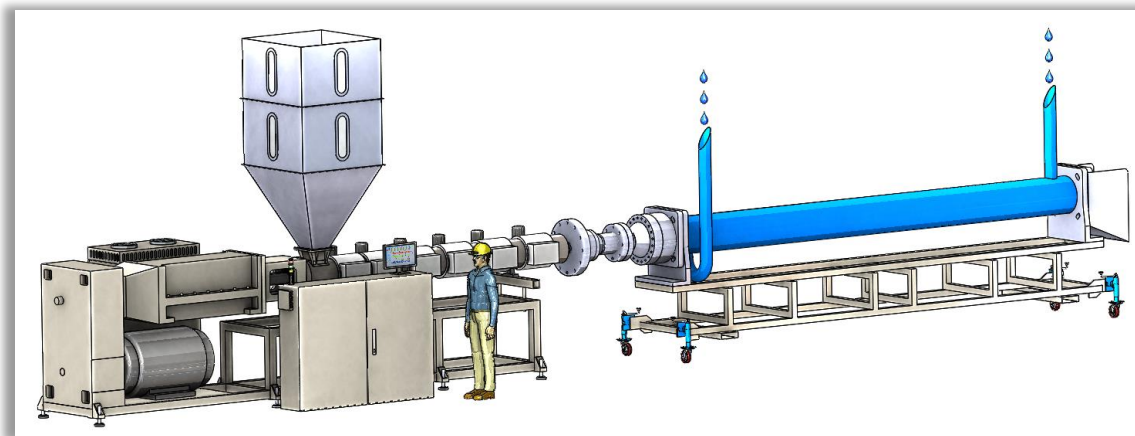

At Rayeman Elements, we strive to be the leaders of the industry not only for our technology and innovations but for our dedication and commitment to you.

Please contact us for more information, and to discuss your project requirements.